

HYDRAULIC SERIES

Snowblowers



HITCH YOUR TRACTOR TO HIGH PERFORMANCE

INNOVATION - QUALITY - STURDINESS



SINCE **1857** DEPUIS

N62-250HYD

N78-250HYD

N102-340HYD

HYDRAULIC SERIES

Snowblowers



N62-250HYD | N78-250HYD

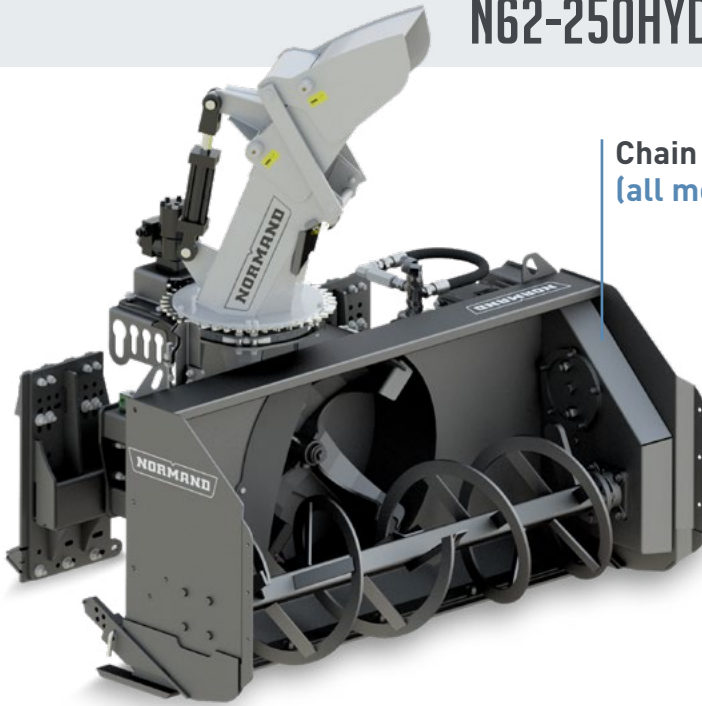

Chain in oil bath
(all models)

N62-250HYD
Without backdrag
(scraper blade)

Backdrag
(scraper blade)



Scraper blade
in raised position



Scraper blade
in down position
Raises the snowblower
up to 3 1/2 inches.

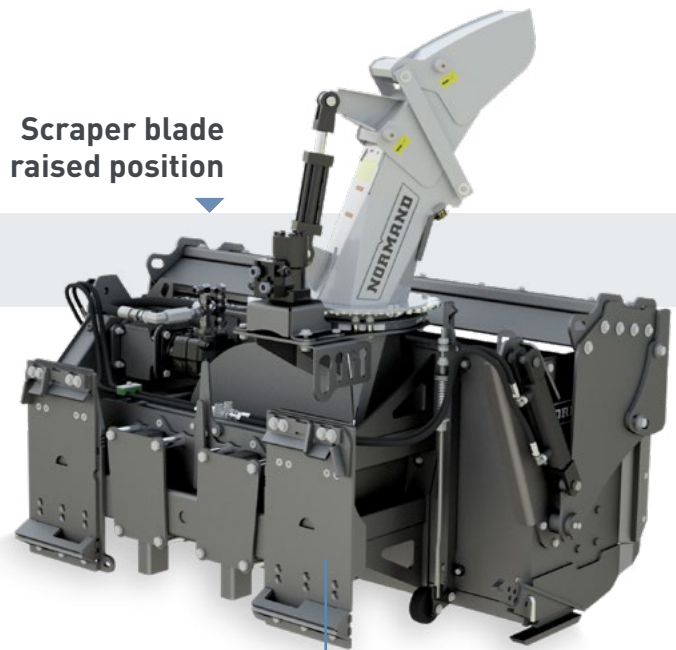

Skid steer
attachment shown

N62-250HYD | N78-250HYD

HYDRAULIC SERIES

Snowblowers



N102-340HYD

Colors (all models)

- Snowblower: husky grey
- Chute: silver

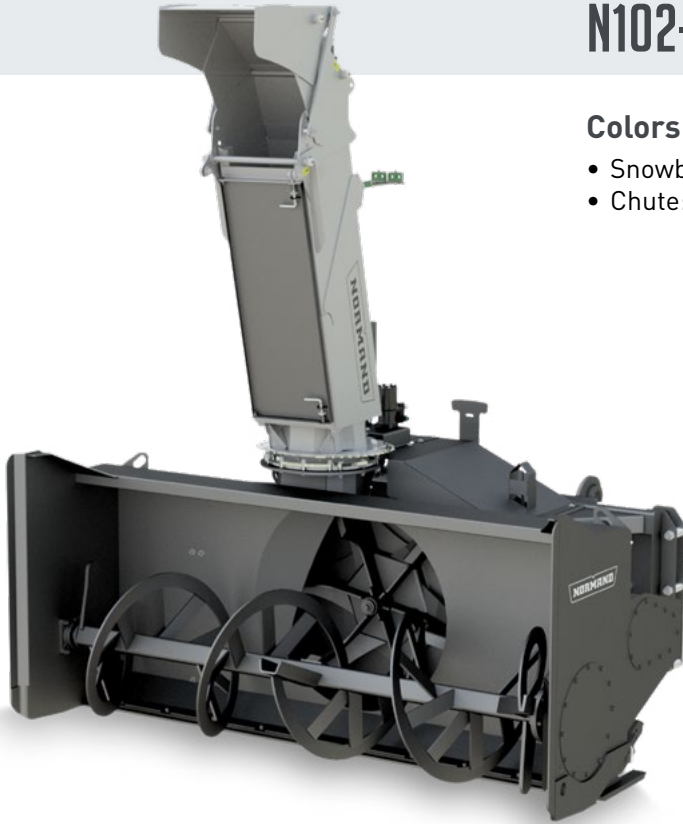

Telescopic chute
(standard) ▶

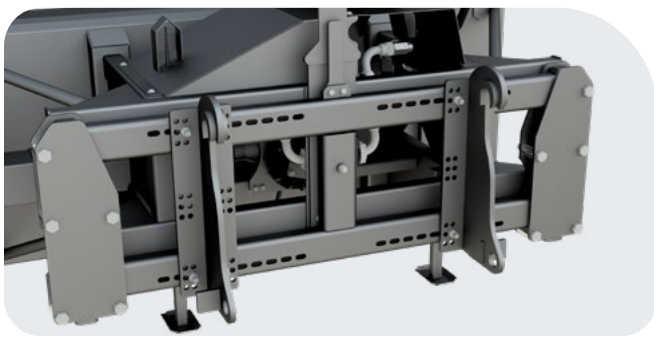
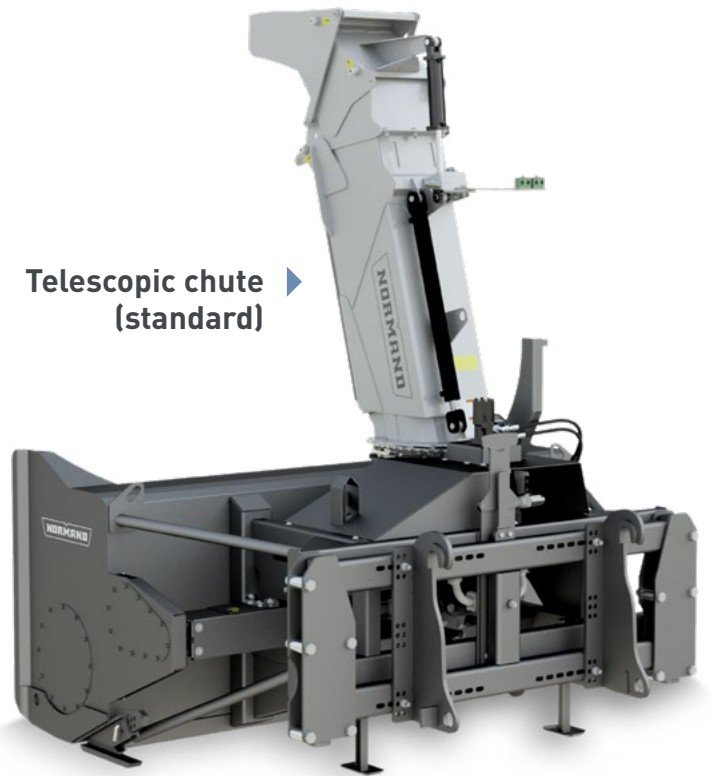

◀ Slip hitch

Allows to follow surface variations and increase efficiency.
(all models)

ADJUSTABLE SKID SHOES

- Carbon steel
- Stainless steel
- **HARDOX 450**
- Tivar 88

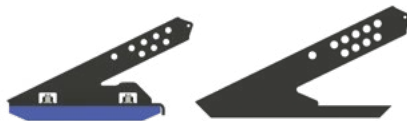

REVERSIBLE CUTTING EDGE

- Carbon steel (reversible)
- Stainless steel (reversible)
- **HARDOX 450** (reversible)
- Tivar 88



N102-340HYD

HYDRAULIC SERIES

Snowblowers



	N62-250HYD	N78-250HYD	N102-340HYD
CUTTING WIDTH	62"	78"	102"
CUTTING HEIGHT	30"	30"	47 1/2"
IMPELLER DIAMETER	25"	25"	34"
IMPELLER DEPTH	9"	9"	12"
NUMBER OF BLADES	4	4	6
IMPELLER SHAFT DIAMETER	1 9/16"	1 9/16"	2"
BALANCED IMPELLER	Std	Std	Std
CHUTE ROTATION BY HYDRAULIC MOTOR	Std	Std	Std
HYDRAULIC DEFLECTOR	Std	Std	Std
SEMI INDUSTRIAL CHUTE	Std	Std	Opt.
HYDRAULIC TELESCOPIC CHUTE	Opt.	Opt.	Std
AUGER DIAMETER	16"	16"	23"
BALANCED AUGER	Std	Std	Std
REVERSIBLE CARBON STEEL CUTTING EDGE	Std	Std	Std
REVERSIBLE 450 STEEL CUTTING EDGE	Opt.	Opt.	Opt.
REVERSIBLE STAINLESS STEEL CUTTING EDGE	Opt.	Opt.	Opt.
TIVAR CUTTING EDGE	Opt.	Opt.	Opt.
LATERAL CUTTING EDGE	-	-	Opt.
ADJUSTABLE CARBON STEEL SKID SHOES	Std	Std	Std
ADJUSTABLE 450 STEEL SKID SHOES	Opt.	Opt.	Opt.
ADJUSTABLE STAINLESS STEEL SKID SHOES	Opt.	Opt.	Opt.
ADJUSTABLE TIVAR SKID SHOES	Opt.	Opt.	Opt.
DUCTILE IRON BEARING CASING	Std	Std	Std
QUANTITY OF SAFETY BOLTS	-	-	2
DRIVE CHAIN	#80 HD	#80 HD	#100
BATH OIL FOR DRIVE CHAIN	Std	Std	-
HYDRAULIC DISTRIBUTION BLOCK CONTROLLING THE ROTATION OF THE IMPELLER AND AUGER, CHUTE ROTATION AND ACTION DEFLECTOR	Std	Std	Std
HYDRAULIC HOSES	Std	Std	Std
HITCH CATEGORY	Skid steer Slip hitch	Skid steer Slip hitch	As per loader type
REAR HYDRAULIC BLADE	Opt.	Opt.	-
14 PINS CONNECTOR INCLUDING WIRING	Std	Std	-
ELECTRO-HYDRAULIC GROUP WITH REMOTE CONTROL FOR ACTIVATION OF AUXILIARY FUNCTIONS	-	-	Std
APPROX. WEIGHT*	1 300 lb	1 450 lb	3 950 lb
REQUIRED LOADER CHARACTERISTICS			
HIGH FLOW MINIMUM	27 GPM to 3 000 PSI	27 GPM to 3 000 PSI	54 GPM to 3 500 PSI
AUXILIARIES HYDRAULIC (2) FOR ROTATION AND DEFLECTOR	Required	Required	-
HYDROSTATIC TRANSMISSION	-	-	Required
24 VOLTS ELECTRIC SYSTEM	-	-	Required

* The weight includes the chute, the rotation kit, the hydraulic cylinder for chute deflector and the hydraulic motor. Specifications are subject to change without notice.

© Normand Company Ltd. All rights reserved 2026



Normand Co. Ltd
cienormand.com



340 Tache Street
 Saint-Pascal (QC) Canada G0L 3Y0
 418 492-2712 • 1 888 666-7626
normand@cienormand.com